



**innovation**  
blinds & shades

E [info@innovationblinds.co.uk](mailto:info@innovationblinds.co.uk)  
T 01444 246090

**PERFECT FIT**  
LOUVOLITE®

## Perfect Fit Roller Blind System - Measuring, assembly & fitting instructions



Before attempting to assemble your unit, please read these instructions carefully.



## Perfect Fit Roller Blind System - Measuring, assembly & fitting instructions

### Clearance & seals

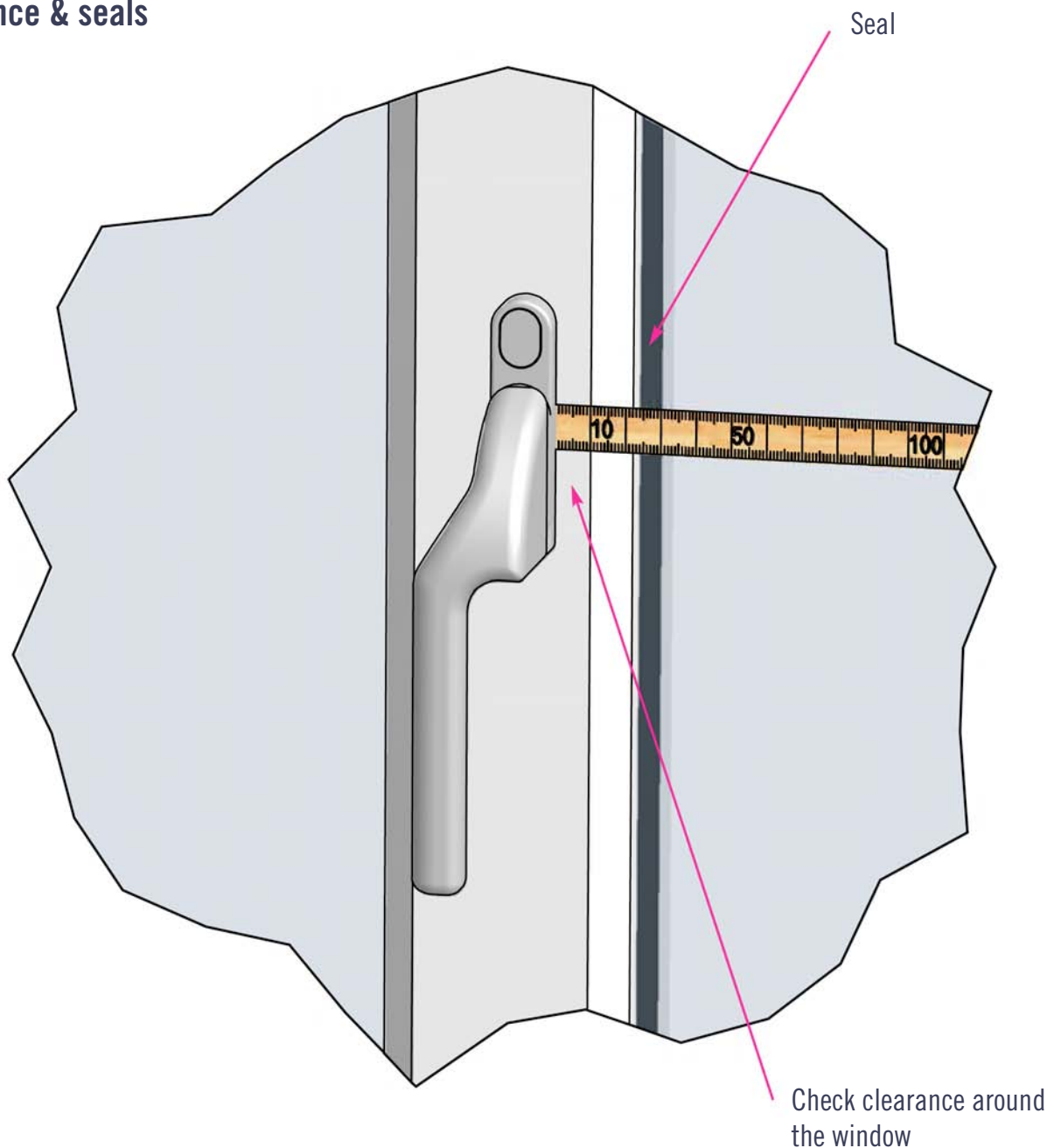

The Perfect Fit framework needs a minimum of 6mm clearance all round the window frame. Seals must not protrude over the glass by more than 6mm. If the seal is compressible, you can take a 'bead to bead' measurement. If not, then take a 'seal to seal' measurement.



## Perfect Fit Roller Blind System - Measuring, assembly & fitting instructions

### Measuring Glass Size

Measure both the width and the drop accurately. We recommend the use of a digital tape measure (P9480)

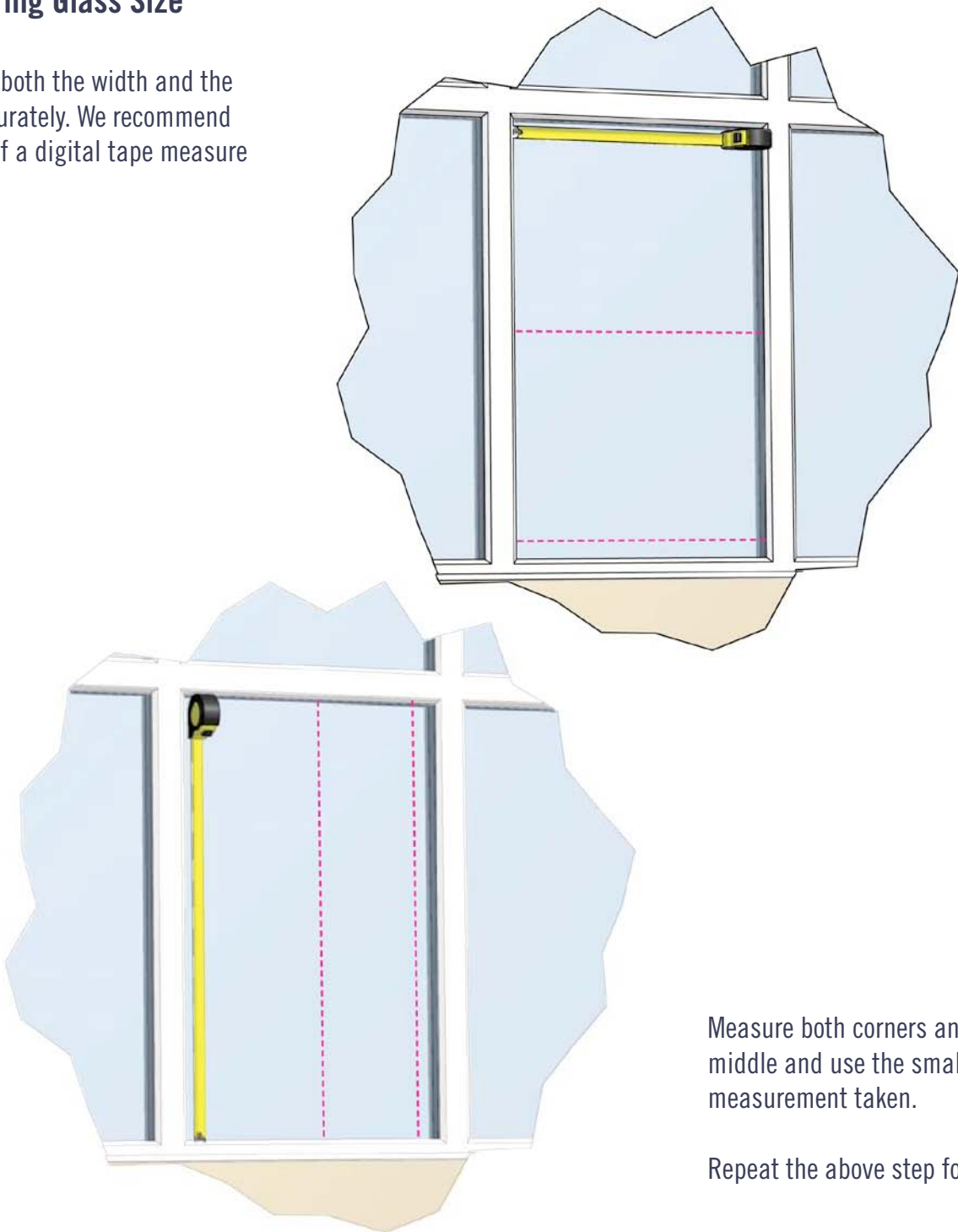

Measure both corners and the middle and use the smallest measurement taken.

Repeat the above step for the drop.



**innovation**  
blinds & shades

E [info@innovationblinds.co.uk](mailto:info@innovationblinds.co.uk)  
T 01444 246090

**PERFECT FIT**  
LOUVOLITE®

## Perfect Fit Roller Blind System - Measuring, assembly & fitting instructions

### Measure Window Depth

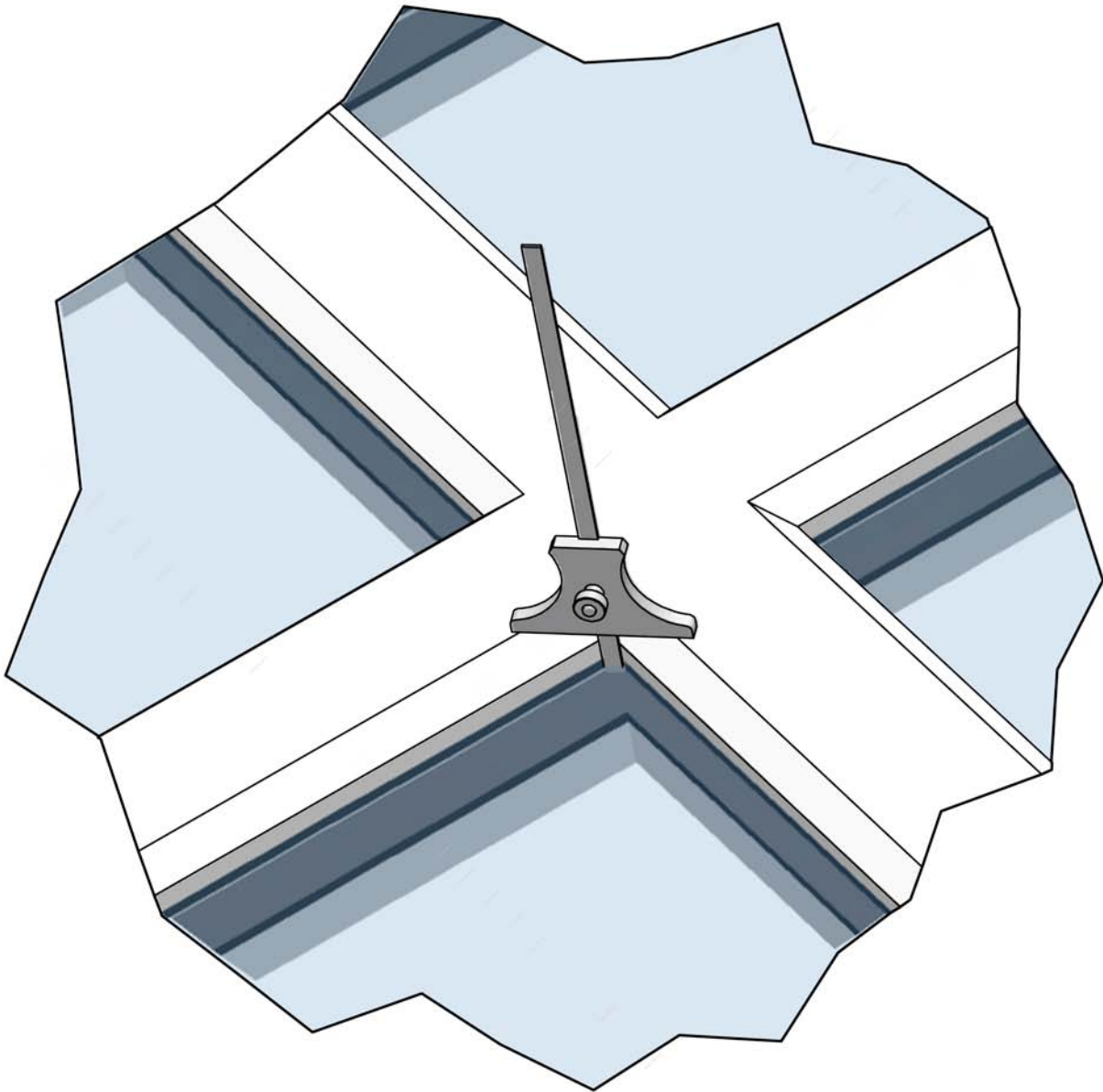

Window depth can be measured using a depth gauge (P9481). This gives you the measurement from the face of window frame to the glass (normally range from 18mm to 24mm)

This will determine the size of the window fixing brackets required.



## Perfect Fit Roller Blind System - Measuring, assembly & fitting instructions

### Fitting Perfect Fit

To ensure all brackets are in the correct position for fitting (85mm from beading) use a credit card in the corner of the window to insert the bracket.

For ease of insertion, use a lubricant in the form of washing up liquid on the base of each bracket.

Line up bracket with edge of card

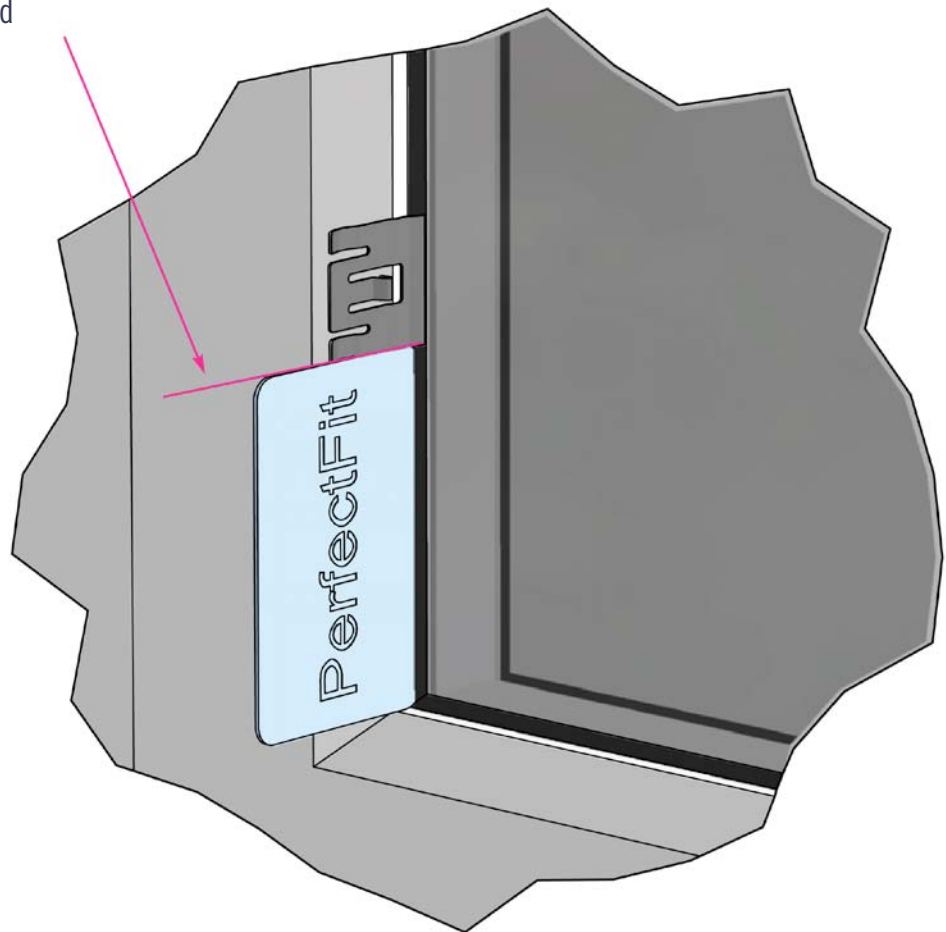

Line up the bracket with the base or top of the credit card (depending on which corner of the window you are working) and fit the bracket by pushing it between the glass and the rubber seal of the window.

Repeat for all 4 corners of the window, and intermediate brackets (if required) then clean excess lubricant prior to fitting the frame.



## Perfect Fit Roller Blind System - Measuring, assembly & fitting instructions

### Fitting the Frame

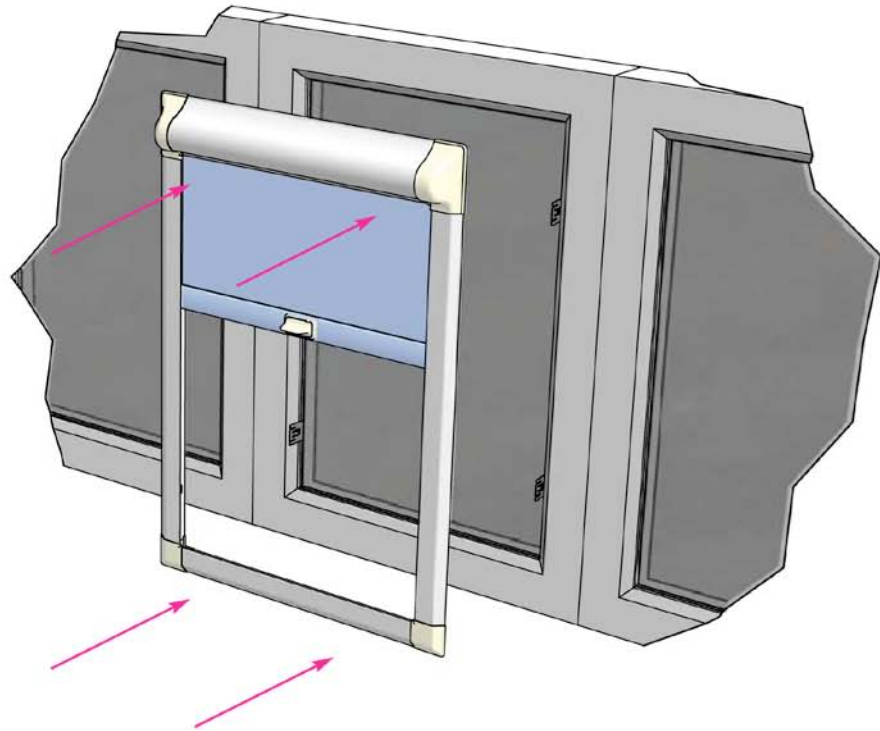

Firmly press down the frame onto each bracket.  
Do one side at a time for an easier installation.

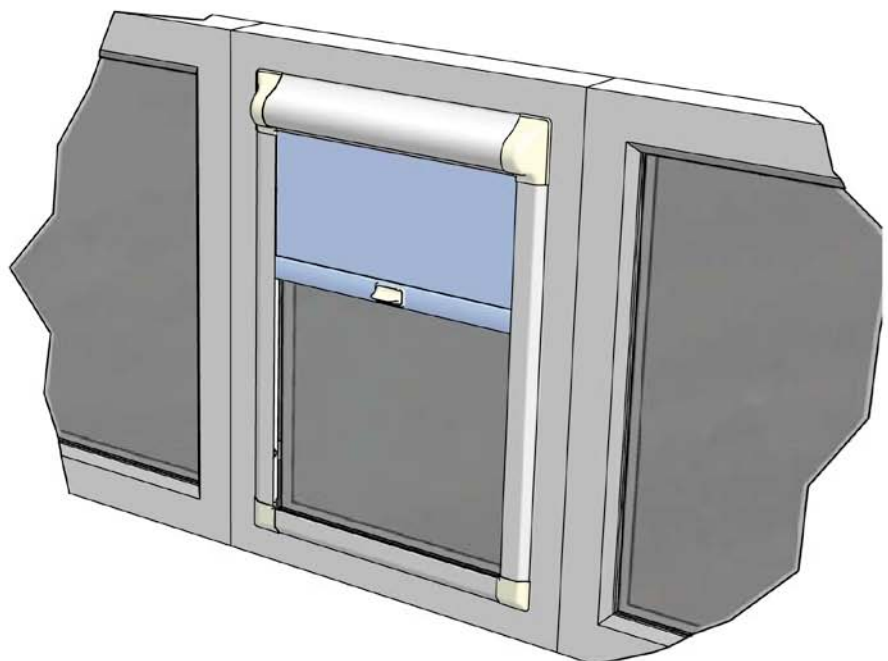

Your blind is now installed.



## Perfect Fit Roller Blind System - Measuring, assembly & fitting instructions

### Re - Tensioning

Remove the frame from the window.

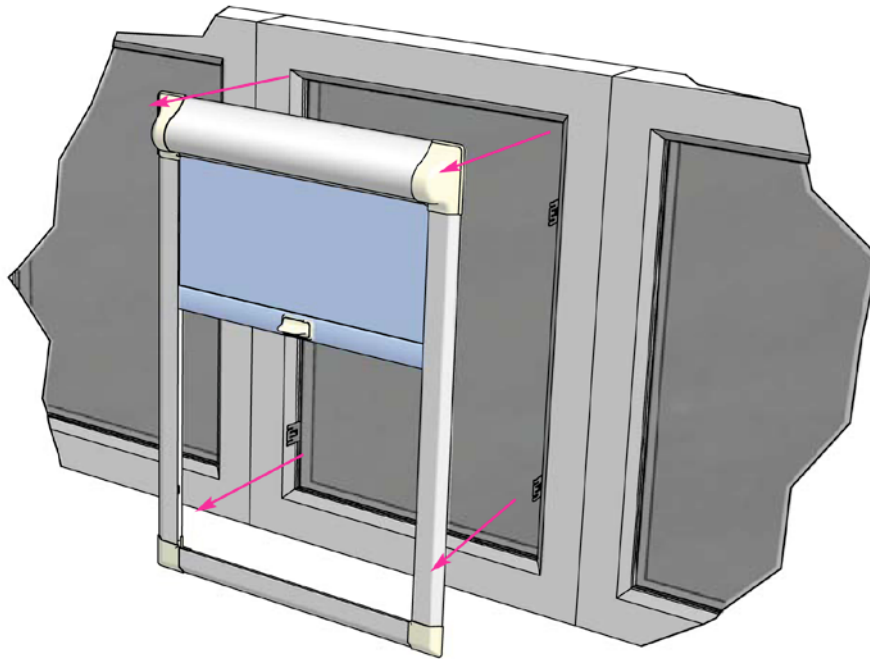

Barrel Clamp

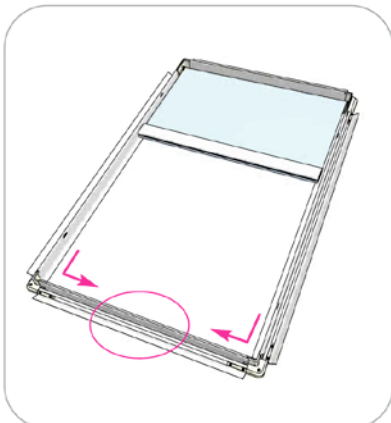
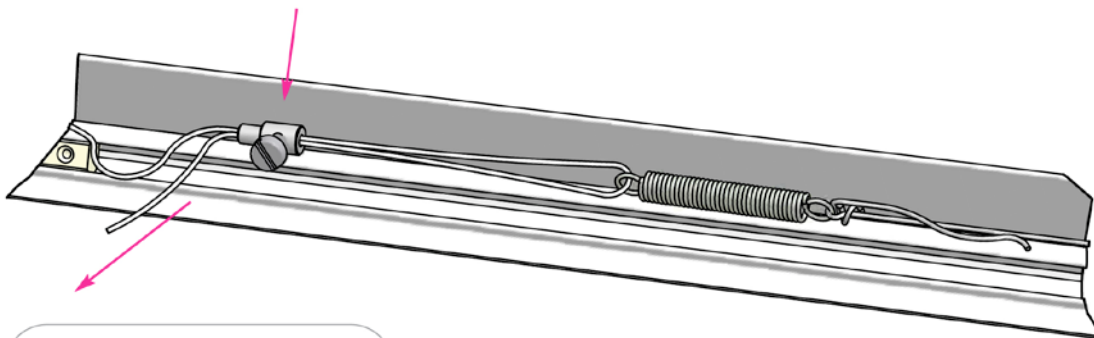

Turn the frame over and release the screw on the barrel clamp.

Pull the loose end of the cord through the barrel clamp to take up the slack and re-tighten the screw to hold the cord in the clamp.

If necessary tighten the cord further to hold the blind down in the lower position.